

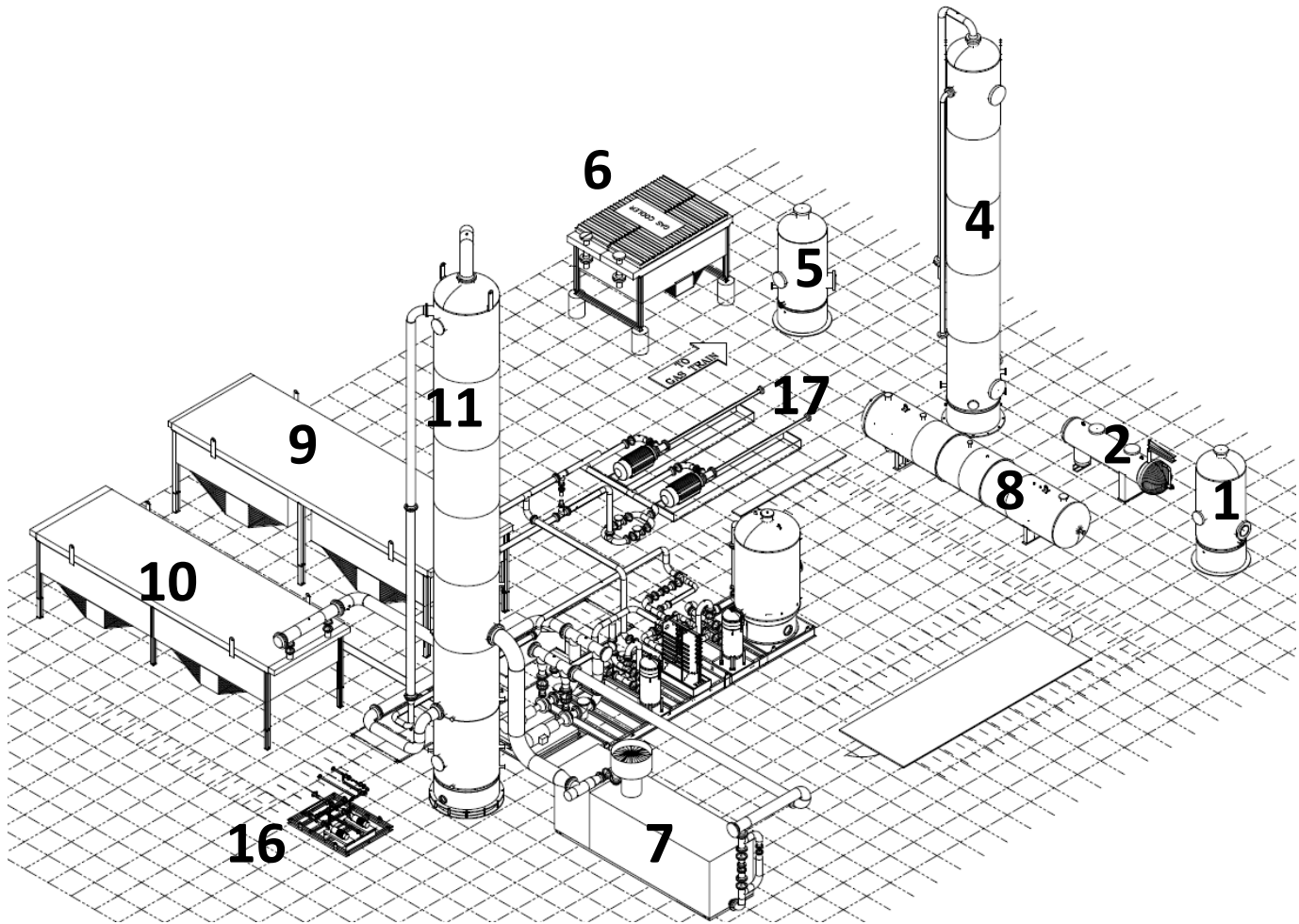

# Gas Sweetening Booklet 300 GPM Amine Plant

# Standard Amine Plant (300 GPM)



- Single or multiple skids
- Main regenerator skid
- Gas train skid or block mounted items
- Main solution pumps skid
- Reflux pump skid
- Coded vessels: ASME Section VIII, PWHT, ANSI B31.1 piping

# Standard Amine Plant Major Components

---

## ❑ Sour gas inlet and gas train

- Pressure 700#-1300#
- Temp 60F – 130F
- If source gas is delivered at higher or lower temperature, an inlet gas cooler may be indicated
- Skidded or block mounted gas train

### 1. Inlet Gas Scrubber or inlet separator

- Separates gas and water or other liquids
- Instrumentation and controls for liquid level and automatic purge (optional)
- It may be located at the bottom of contactor

### 2. Inlet Gas coalescing filter separator

- Separates gas and water or other liquids
- Instrumentation and controls for liquid level and automatic purge (optional)

### 3. Gas – Gas exchanger

- Establishes the gas temperature for optimal performance inside the amine contactor

### 4. Amine Contactor

- The item where the chemical reaction of amine and acid components (CO<sub>2</sub>, H<sub>2</sub>S) takes place
- Sized for the actual gas flow
- O.D. diameter up to 84", typical height 60'
- Trays sized for optimal performance and high turndown ratio (standard 4:1, optional up to 10:1)

# Standard 300 GPM Major Components

---

## 5. Amine Scrubber

- Designed to remove amine particles left after still column and reflux condenser
- May be located at the bottom of the still column

## 6. Outlet gas cooler

- Establishes the gas delivery temperature downstream the amine plant

## □ Amine Regenerator

- Part of the plant where the release of acid components from solution takes place, and the amine is regenerated for reuse

## 7. Amine Heater, Reboiler and heat medium skid

- Direct fired heaters (preferred) or hot oil system
- All heaters with integral NFPA burner management panel
- For hot oil systems:
  - Heat medium skid with pumps and expansion tank
  - Shell and tube reboiler with level and pressure transmitters, safety relief valves, temperature and level controls

## 8. Amine Flash Tank

- Designed to operate after amine contactor
- It settles the process parameters at lower pressure, after the pressure control valve

## 9. Amine Cooler

- Cools the lean amine after regeneration, before being re-injected in the contactor

# Standard 300 GPM Major Components

---

## 10. Reflux Condenser

- Designed to condensate the amine from the overhead gas out of still column

## 11. Still/reflux accumulator

- Two in one construction, with still column to separate and recover the lean amine from rich solution

## 12. Carbon filter

- Designed to remove and absorb traces of hydrocarbons from the amine solution

## 13. Lean/rich amine solids filters

- Designed to remove the solid particles from the amine solution, in order to prevent clogging of the plate and frame lean/rich exchanger

## 14. Lean/rich exchanger

- Designed to cool the lean amine before being reused, and to heat the rich amine before the still column

## 15. Amine Booster pumps

- Designed to ensure the minimum NPSH for the main solution pumps

## 16. Reflux pumps

- Designed to remove the amine solution that condensed in condenser

## 17. Main solution pumps

- Designed to ensure the high pressure necessary to inject the amine solution inside the amine contactor

# Standard 300 GPM Major Components

---

## ☐ **Electrical and controls**

### **18. PLC panel**

- Designed to host the PLC and auxiliary equipment, and to ensure communication and link with the skid junction box

### **19. Instrumentation**

- Designed to remove amine particles left after still column and reflux condenser
- May be located at the bottom of the still column

## ☐ **Documentation**

- Drawings and P&ID's
- Process simulation
- Cause and effect diagram, PLC program and operator interface
- Weight and dimension list
- Instrument list and calibration values
- All coded required documents for pressure vessels: U1A forms, hydro charts, engineering calculations available
- Curves for pumps, rating sheets for heat exchangers
- Control valves and PSV sizing and calculations
- Manuals for pumps and instruments

## ☐ **Startup assistance**

- Ensured within continental US

## ☐ **Warranty**

- 12 months from commissioning or 18 months from delivery (FOB Odessa, TX)